

Simmons and the Strain Gage

FIFTY YEARS AGO this month a former Caltech graduate student invented, almost casually, a device that caused an engineering revolution. Although some date the birth of the bonded wire resistance strain gage to 1938, Edward E. Simmons, Jr., actually first conceived it in 1936. When the outside world discovered its existence three years later, the versatile instrument found immediate, enthusiastic acceptance, first in an aircraft industry hard-pressed by the demands of World War II and eventually in all industries where stress analysis is crucial. Strain gages based on Simmons's prototype are still in widespread use today. Simmons (BS '34, MS '36 in electrical engineering), although offered research jobs elsewhere, determined to be a free-lance operator and chose to remain in Pasadena in the house he has inhabited since 1934. He's a familiar figure around the Caltech campus, which he considers a "suitable local amusement park."

Components of all machines and structures are subject to strain that can deform them — tension, compression, bending, and twisting. Ever since the time of Robert Hooke and Isaac Newton, scientists and



engineers had been trying with only limited success to devise ways to measure this strain accurately and conveniently. Even in the first third of the 20th century experimental stress analysis was in a relatively crude state. Design engineers had to compensate for the lack of accurate information by providing extra strength and sometimes extra weight to, say, airplane propellers or bridge girders, to insure against failure.

"Engineers had wanted something like this since the pyramids were built," wrote Francis G. Tatnall, who first recognized the commercial potential of Simmons's innovation and who, rightly or wrongly, is known as the

Edward Simmons stands on the spot where he invented the strain gage 50 years ago. It was then a cubbyhole office on the first floor of Throop Hall.

“father of the strain gage.” Tatnall, then testing-machine sales manager and later research director of Baldwin Southwark Division of the Baldwin Locomotive Works in Philadelphia, had long been prowling universities in search of the perfect strain gage — “zero length, zero thickness and . . . almost zero price.”

Howard A. Nielsen, Jr., in his history of Baldwin, *From Locomotives to Strain Gages* (Vantage Press, 1985), describes Tatnall’s “bootleg research”: “He would ferret out the testing-equipment innovators, hidden in cluttered offices in remote corners, conceiving equipment they needed to do their daily jobs. Then he would promptly sign them up for Baldwin to market their product worldwide, leaving the dazzled inventor breathless.” Nielsen’s book describes how Baldwin, the leading manufacturer of steam locomotives, opportunely and without investing a dime (thanks to Tatnall’s “research”), fell into the testing-equipment business just as loco-

tives were dying out. Nielsen, who worked for Baldwin from 1946 to 1957, admits that there exist “certain aspects of early strain-gage history that are fuzzy in the mists of time, memory, and legalisms.” But most accounts agree on the actual discovery. Tatnall’s own book, *Tatnall on Testing* (American Society for Metals, 1966), contains lengthy passages devoted to his joy at unearthing Ed Simmons at Caltech in August 1939.

Simmons was then occupied part time constructing electrical equipment for Donald S. Clark, assistant professor of mechanical engineering, in his Impact Research Lab, a program sponsored by several commercial firms starting in the fall of 1936. At that time his campus reputation for ingenuity had already made him a magnet for problems that required creative solutions. So Clark and Gottfried Dätwyler, research fellow in aeronautics, asked Simmons to construct an impact dynamometer — “a device for translating instantaneous forces into instantaneous electrical impulses which could be recorded on an oscillograph” — basically a strain gage. Within the first few days of September, Simmons conceived and designed it. “It was a flash-of-genius sort of thing,” says Simmons, “and it turned out astoundingly well.” He told Tatnall that since he hadn’t known it couldn’t be done, he just did it.

What Simmons did was to take advantage of Lord Kelvin’s 1856 discovery that electrical resistance in a metal wire changes when it is stretched and its length and diameter change. This can be expressed as a ratio; for example, stretching a wire 0.1 percent might produce a change in resistance of 0.17 percent. Strain or distortion in a structure would stretch a thin wire attached to it, and the change in resistance could be measured. Simmons was not the first to exploit this idea for a deformation gage; Roy Carlson, a Caltech student in the early 1920s, had invented a gage that found use primarily on dams. In Carlson’s instrument each end of a wire was attached to a separate point on the structure to be tested, a procedure that measured the average strain over a relatively large gage length. Simmons’s solution was to attach the entire length of a fine wire (smaller in diameter than a human hair) to the test object by first zigzagging the filament into a grid a fraction of an inch long and then cementing it down with glue. Lead wires then connected it to a device, such as a Wheatstone bridge, to measure the electrical resistance, which could

Simmons’s original invention — “a new type of tension dynamometer” — was described in a paper by Clark and Dätwyler published in the Proceedings of the American Society for Testing Materials annual meeting in 1938.

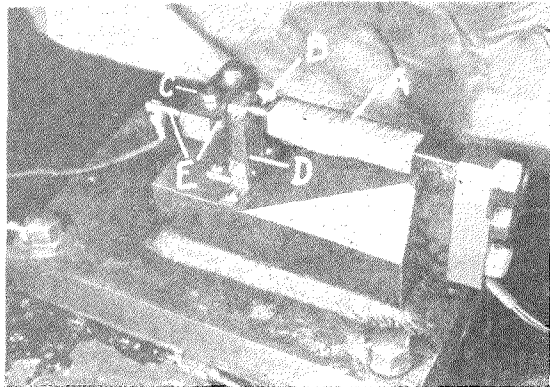

In the 1933-34 California Tech Simmons is standing third from left in the front row of the student branch of the American Institute of Electrical Engineers.

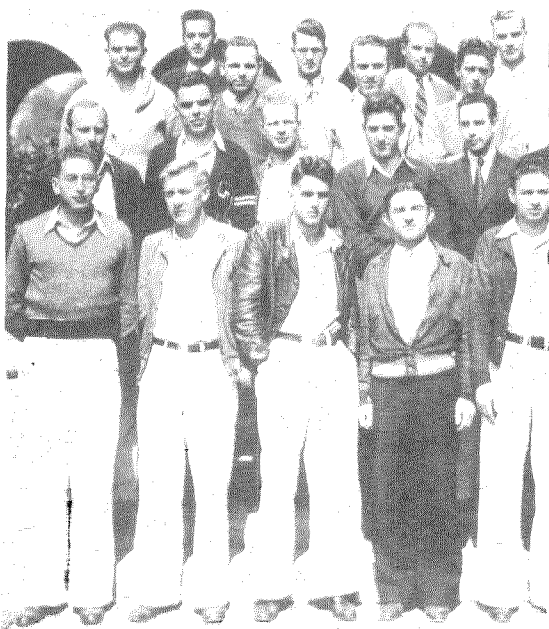

Fig. 1

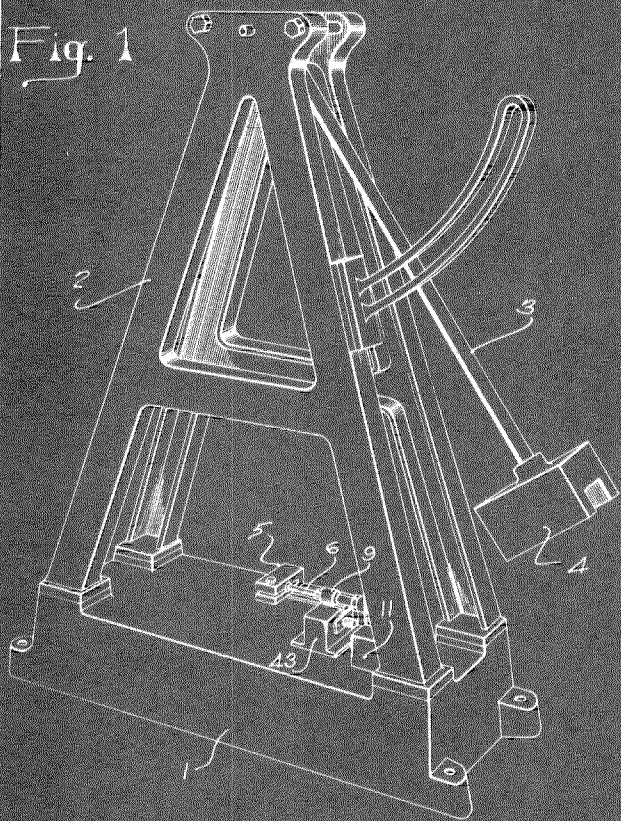

Fig. 10

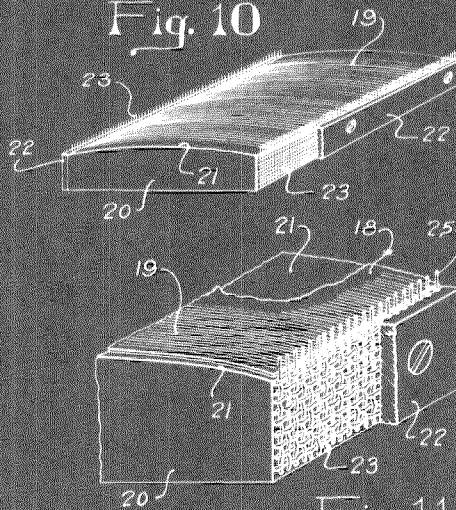

Fig. 11

Fig. 9

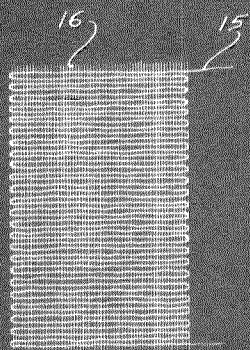
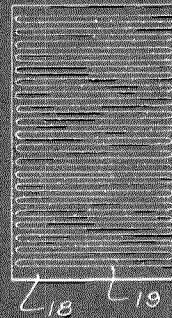

Fig. 13

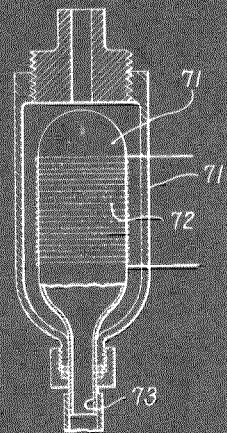

Fig. 14

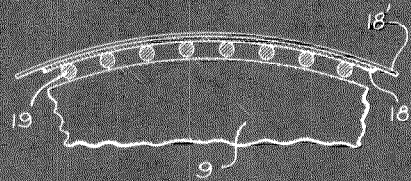

Fig. 12

INVENTOR
SIMMONS

BY
Edward M. Wickaway
ATTORNEY

Filed with the 1944 patent application for a "Material Testing Apparatus," this drawing shows the impact testing device and several versions of Simmons's wire gage.

be recorded. It came close to measuring the strain at a point. And it was elegant and simple.

Tatnall admired elegant thinking. When, after hearing rumors and pursuing Clark for a couple of years, he finally tracked down Simmons in his garage, he could appreciate the beautiful simplicity of the device amid its chaotic surroundings. "He [Simmons] picked up from a rough tabletop a most amazing collection of wire gages in various configurations, bonded and unbonded, some like Lilliputian stringed instruments . . . others laid down on old Christmas cards. . . . When I extracted patiently from Simmons a description of what he had done I could hardly contain my enthusiasm."

Tatnall had earlier discovered Arthur Ruge of MIT, who had invented a similar device sandwiched between two pieces of paper the size of a postage stamp, and the Baldwin Locomotive Works had already applied for a patent in Ruge's name. When Tatnall brought the Caltech and MIT groups together, it became clear that Simmons had done it first. Tatnall suggested naming the new strain gage SR-4 (S for Simmons, R for Ruge, and 4 for the four men involved, including Clark of Caltech and A. V. deForest of MIT). Baldwin Southwark changed its application to a basic patent for Simmons and a string of improvement patents for Ruge. Each remained protective of his piece of the pie, according to Nielsen, whose job it was to keep track of the patents, and he had Simmons and Ruge "both breathing hotly down my neck."

The patent problems, unfortunately, did not end there. Although Simmons, at Clark's behest, signed an agreement in 1940 assigning royalties and license approval to Caltech, he claimed later that it was with the understanding, through Clark's promises, that the royalties would be channeled into the Impact Research program and that he would be employed in that program on a regular basis. When first Simmons and then the entire program were terminated in 1941, it turned out that the royalties had gone into the general fund of the Institute, which was apparently unaware of Clark's promises and didn't consider him empowered to make any anyway. The now unemployed Simmons, who had previously lacked interest in the business end of things, hired a couple of young lawyers (a friend he had known in the Boy Scouts and a law school classmate of his) and sued for the

rights to all royalties. The case went all the way to the California Supreme Court, which finally decided in Simmons's favor in 1949, enabling him to collect \$125,000 in impounded back royalties. Total royalties over the 17-year span of the patent amounted to close to \$1 million.

While the wheels of justice were slowly grinding, Simmons had worked as a radar engineer at the Sacramento Air Depot during the war and then returned to Pasadena to work for the Rheem Manufacturing Company. But the court decision changed all that. According to Tatnall's account: "After this, when I was looking for Ed Simmons I would find him dressed like a tennis player in his law library that he had accumulated for study during the trial. While Ruge-deForest pushed ahead with the strain gage and transducer business, Ed Simmons read law, set up a 'Simmons Research Foundation,' went into the oil prospecting business with a friend and came out with two gushers. He took up skin-diving and cave exploring in a quiet, persistent way, became an expert 3-D photographer with Viewmaster equipment. . . . He involved himself successfully in setting up a wire music service for restaurants; he did everything but follow up on the strain gage business."

The strain gage business did, however, apparently leave its mark on Caltech's patent policy. Clark and others at Caltech had been under the impression that the Institute owned the rights to anything developed there, but there had been no formal policy. In 1943 the Board of Trustees adopted a resolution to require a written invention agreement of employees. Current policy stipulates that employees assign to Caltech "inventions made in the line of Institute duty or with the use of Institute facilities."

Under Tatnall's zealous marketing strategy, the SR-4 strain gage went on to fame and fortune. Because of the tiny gage's insignificant cost, testing engineers could plaster them all over a structure and then pitch them out afterwards. Aircraft companies on the West Coast were using the device as soon as news of it got out, even before the patent application. A Lockheed engineer called it "the most sensational advance for aircraft design that had yet appeared" and predicted its use would move like wildfire. It did; Tatnall describes "strain gage fever" spreading eastward. A prominent speaker at the New York annual meeting of the Institute of the

Aeronautical Sciences in 1943 proclaimed: "The SR-4 strain gage has been the greatest single contributor to the present efficient airplane structure, thereby strongly aiding Allied air supremacy."

Since World War II SR-4 strain gages have found application in the automobile and railroad industries, on bridges, buildings, and highways, on all types of machinery, and in the design of almost any new equipment or structure that must undergo stress. They are also an essential component of electronic weighing equipment. Now 150 different types of strain gages are commercially available in a business worth a half-billion dollars per year.

Even though Simmons abandoned the strain gage business after seeing his patent through the courts, his role in its invention did not go unrecognized. Tatnall, who had great admiration for the original thinking of attic inventors like Simmons, nominated him in 1944 for the Edward Longstreth Medal of the Franklin Institute of Philadelphia, which awarded about 15 medals each year for "contributions to the arts and sciences of the world, to the good of mankind and to the advancement of science." The Franklin committee cited Simmons for his "valuable contribution to engineering and research. . . . [his device] has proven essential in engineering design of aircraft and other powerful instruments of war, and will be as valuable in peace."

In his book Tatnall described the ceremony: "Medal Day begins with a formal luncheon at noon followed by meetings with the Medalists, press conferences for them, publicity photographs and other customary formalities. Simmons did not show up, so I just explained that he was embarrassed, knowing that he wasn't at all, he just did not care. Simmons was still absent when we dressed for dinner, Medalists in white tie and tails, others in black tie. When the Medalists filed into their designated places at the head table, I had not the nerve to look to see if my boy was at his place at the table. When I did get up nerve to look my heart jumped with joy. There he was sitting between the great chemist, Dr. Leo Baekeland, inventor of Bakelite, tall, mustached and impressive, and on the other side Dr. Harlow Shapley, famous astronomer, director of the Harvard observatory, both in white tie and tails. Ed Simmons was looking very small, very young and very bored and he was in his familiar tennis clothes, or a slightly enhanced version of



Simmons (left) and Arthur Ruge of MIT, the "S" and the "R" of the SR-4 strain gage, shake hands at the 1964 Los Angeles meeting of the Western Regional Strain Gage Committee. This took place 25 years after the original patent agreement.

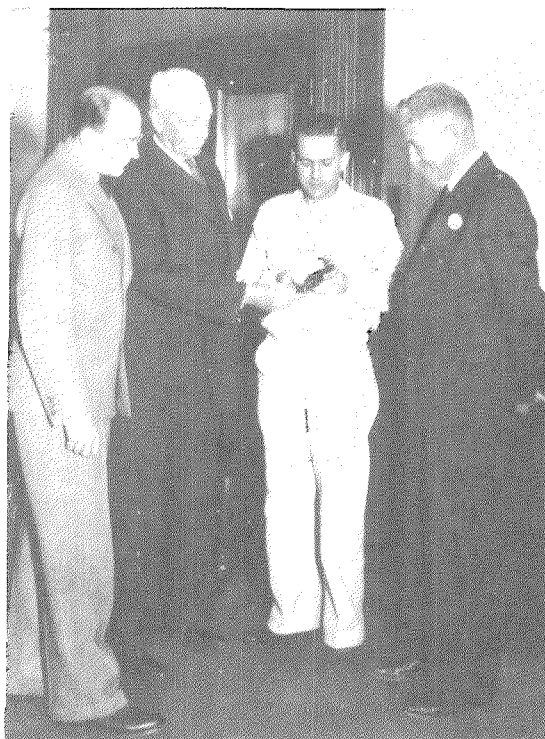

Simmons (second from right) displays his 1944 Longstreth Medal to executives of the Baldwin Locomotive Works. Frank Tatnall stands at right.

them. As each Medalist would receive his medal and scroll from the President of the Franklin Institute, each would graciously acknowledge with a word or two — except Ed Simmons, who said nothing at all and looked tired. I think, but I am not sure, that he got the biggest hand of all from the 450 or more prominent people attending the dinner. Those of the Institute and committee members present seemed to feel that I had done the Institute a favor by letting them see in person an inventor that looked like a traditional, historic type, a Diogenes. After this, let me hear no one criticize the dress or nonconformities or little singularities of E. E. Simmons, Jr., for I am one of his fans." □ — JD